

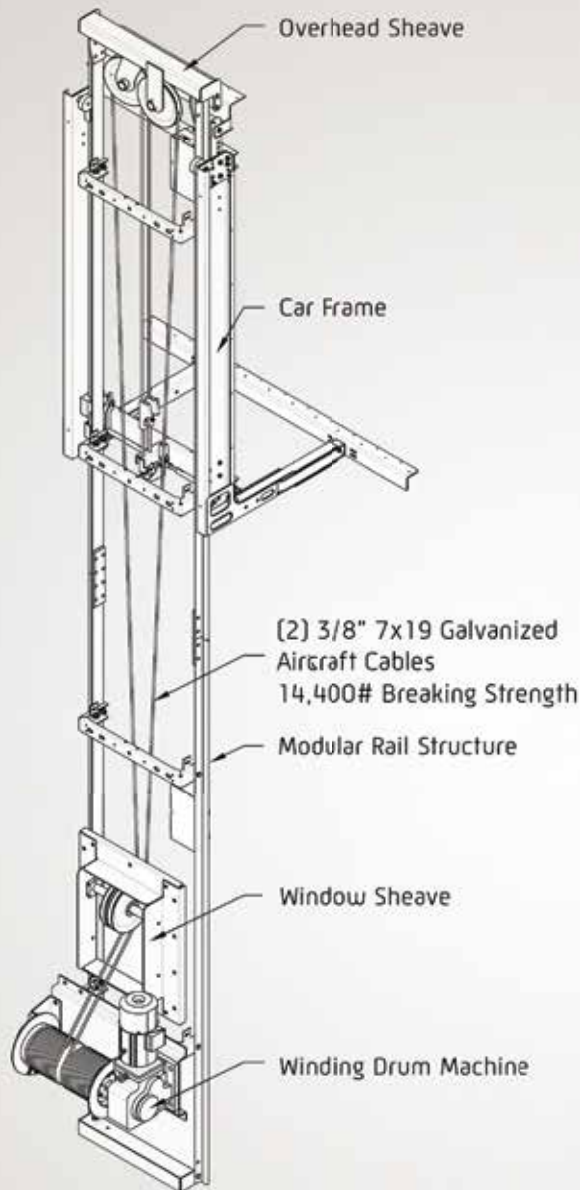

Made in the USA

Symmetry Residential Elevator Winding Drum Drive



 **symmetry**
ELEVATING SOLUTIONS
National Reach. Local Service.®



www.symmetryelevator.com

Smoothest, quietest winding drum drive on the market

With more standard features than any other elevator available, the Symmetry Elevating Solutions Winding Drum Drive is the industry leader. We offer battery lowering, digital position indicators on the COP and hall stations, custom wood sills and LED lighting as standard features. Our custom options lead the industry, as well.

Standard Features:

- Travel: 50' maximum (12" minimum between stops)
- Speed: 40 FPM
- Load Capacity: 1000#
- **Overhead: 7'10" [94" minimum with remote controller]**
- Pit depth: 6" minimum (8" preferred)
- Two (2) stops
- Single opening
- Three (3) year limited parts warranty

Mechanical Equipment

- Modular 6-1/4# T-rail structure
- Car frame assembly
- 208/230 VAC, 60Hz, 30 Amp single phase power supply for motor controller
- 120 VAC, 60Hz, 15 Amp single phase power supply for lighting
- Two (2) 3/8" 7x19 galvanized aircraft cable (14400# breaking strength)
- Inverter controlled variable speed geared assembly with winding drum drive unit and 3 HP motor
- **Code compliant electrical disconnects included**

Safety Features

- Slack rope safety device
- Motor controller supply disconnects (located in controller)
- Car light supply disconnects (located in controller)
- Pit stop switch
- Car top stop switch
- In-car emergency stop switch and alarm
- Safety switch for car gate(s)
- Battery back-up emergency car lights
- Uninterruptible Power Supply – (UPS) for car lowering and automatic gate operation (if autogate operator provided) in the case of power failure (to allow emergency lower of cab in case of main power failure)
- Electromechanical hoistway door interlocks (doors by others)
- Light curtain monitoring the car entrance

Controls

- Programmable Logic Controller (PLC)
- Non-selective collective automatic operation
- **S.M.A.R.T System (Self-Monitoring Alert Response Technology)**
- Car Operating Panel (COP) with LED floor position indicator; available in multiple finishes
- Recessed phone box in multiple finishes (phone jack included)
- Hall stations with call button and LED floor position indicator; available in multiple finishes
- Automatic car lighting
- Single floor designated car homing

Car Features

- Cab size up to 15 square feet
- 7'0" interior car height
- **Birch, Oak or Maple flat veneer interior walls with matching ceiling**
- Matching wood handrail
- Matching wood car sill
- Unfinished plywood floor with sill set for .75" (flooring by others)
- **Two (2) energy saving recessed LED lights with black trim rings**
- 7'0" vinyl laminate accordion gate (light oak, dark oak, birch, white, chalk, or antique white)

Optional Features

- Up to six stops
- Travel of 60' possible with approval from the AHJ and a reduced capacity
- Single automatic push button operation
- Custom car size up to 18 square feet*
- Custom car heights
- Shaker or Recessed panel car with flush ceiling
- Shaker or Recessed panel car with matching ceiling
- Raised panel car with matching ceiling
- **Four recessed LED lights with black, brass, nickel or bronze trim rings**
- Factory finished car
- Polished stainless steel, polished or brushed brass, black, vintage bronze and oil rubbed brass fixtures (including COP, phone box, hall calls, and handrail)
- **COP with integrated keypad phone**
- Custom wood interiors
- **Custom factory finishes (antiqued, distressed, and crackle)**
- **Green material alternatives and finishes for car interiors**
- Symmetry Safety 3 Panel Car Door
- Two and three speed car or car and landing doors
- Wrap around car door
- Enterprise collapsible gate
- Scissor gate
- Hardwood veneer accordion gate
- Clear panel accordion gate
- Automatic car gate/door operator (not available on Enterprise collapsible gate)
- .75" finished or unfinished factory installed hardwood car flooring
- Factory flooring insert for 1/4" flooring by others
- Buffer springs (requires minimum of 8 1/4" pit depth)
- Key switch for COP and hall stations
- 750# car capacity
- Accordion gates will have bronze hardware except on white, chalk, or antique white gates. Acrylic gates will have clear hardware when stainless or black fixtures are provided.

Red (•) denotes Symmetry Elevating Solutions exclusive

** This symbol denotes features may require local code authority approval*

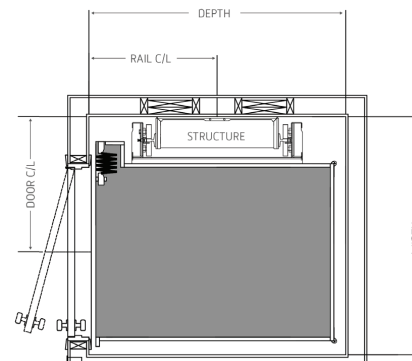

Single Opening
Rail Left, Right Hand Door / Rail Right, Left Hand

Car Size	Width	Depth	Rail C/L	Door C/L	Clear Opening
36 x 48	50.5"	54.5"	27.25"	28.75"	32.25"
36 x 60	50.5"	66.5"	33.25"	28.75"	32.25"
40 x 54	54.5"	60.5"	30.25"	32.75"	33.5"

Division 14 Specs:

Offers a custom specification generator created to easily 'build' Division 14 products. SpeCreator™ generates product specific sets of CSI 3-part specifications.

SpeCreator™:

SpeCreator™ generates product specific sets of CSI 3-part specifications.

This brochure is intended for informational purposes only. Consult local code authority before beginning construction before beginning construction



National Reach. Local Service.®
877.375.1428 | SymmetryElevator.com

105.05/16



Want to Learn More?

Scan this QR code with your smart phone to access the entire Symmetry Elevating Solutions product line.