

# Inline Gear Drive

Machine Room & Machine Room-Less Residential Elevator Applications

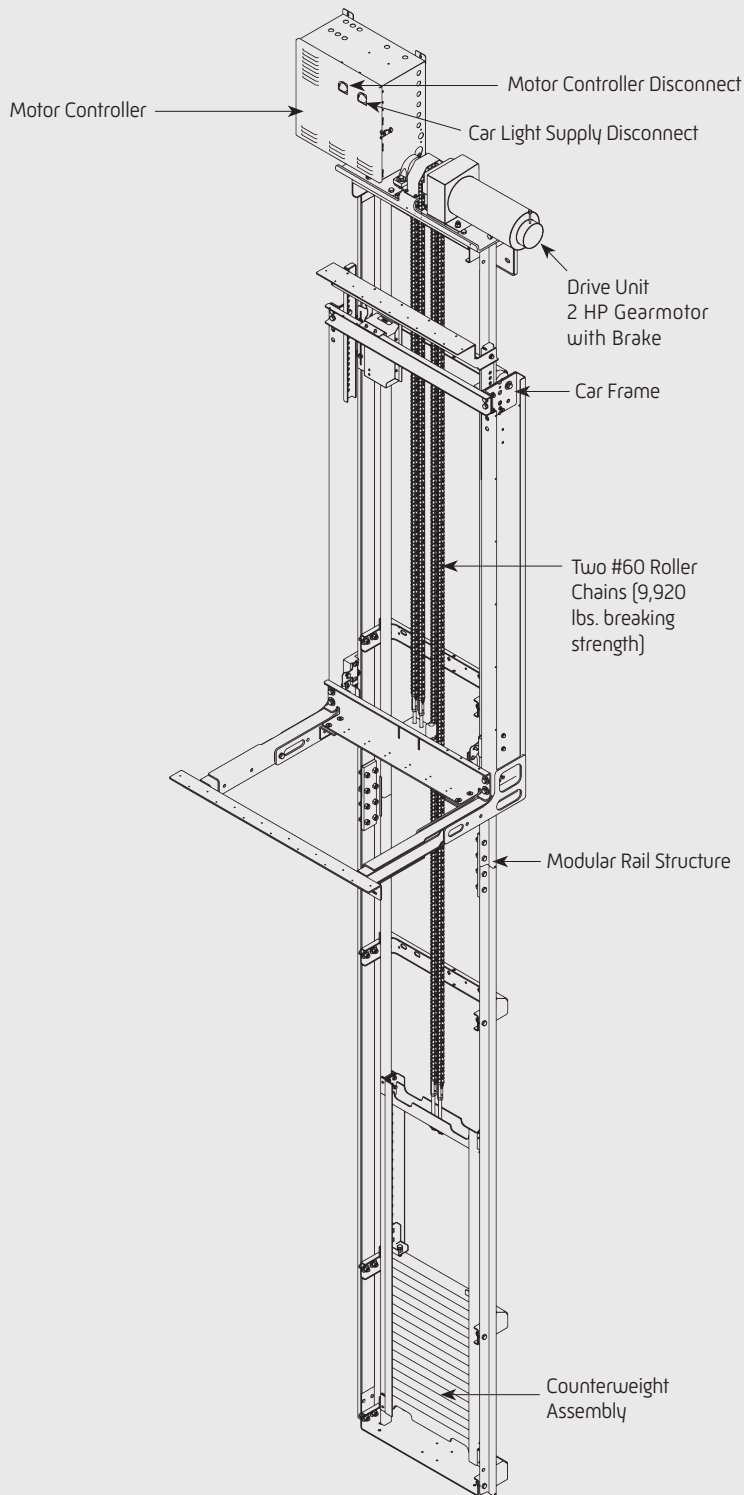

## Industry Leading Warranty

- Three-year limited parts warranty

# Fits Where Others Won't.

With more standard features than any other residential elevator available, the Symmetry Elevating Solutions Inline Gear Drive is the industry leader. We offer battery lowering, digital position indicators on the COP and hall calls, custom wood sills and LED lighting as standard features. Our custom options lead the industry, as well.

## Standard Features

- Travel: Maximum of 50'0" (minimum 12 inches between stops)
- Speed: 40 fpm
- Rated capacity: 1,000 lbs.
- Overhead minimum of 8'0" (96 inches) with remote controller; minimum of 9'0" with controller in hoistway with a 7'0" interior car height
- Pit depth: 6" minimum (8 inches preferred)
- Two stops
- Single opening
- Three-year limited parts warranty

## Equipment

- 208/230 VAC, 60 Hz, 20 amp, single-phase power supply for motor controller
- 120 VAC, 60 Hz, 15 amp single-phase power supply
- Code-compliant electrical disconnects included\*
- Inverter-controlled variable speed Inline Gear Drive unit with counterweight and 2 HP motor
- Two #60 roller chains (9,920 lbs. breaking strength)
- Car frame assembly
- Modular 6¼ lb. T-rail structure
- Manual lowering device

## Safety Features

- Slack chain safety device
- Two upper and one lower final limits
- Machine stop switch
- Motor controller supply disconnect (located in controller)
- Car light supply disconnect (located in controller)
- Pit stop switch
- Car-top stop switch
- In-car emergency stop switch and alarm
- Safety switch for car gate[s]
- Battery backup emergency car lights and alarm
- Electro-mechanical hoistway door interlocks (doors by others)
- Light curtain monitoring the car entrance †

## Controls

- Programmable Logic Controller (PLC)
  - Located in shaft in machine room-less application
  - Located within 50 feet of motor in machine room
- Non-selective collective automatic operation
- S.M.A.R.T. system (Self-Monitoring Alert Response Technology)\*
- Car Operating Panel (COP) with LED floor position indicator‡
- Recessed phone box (phone jack included)§
- Hall stations with call buttons and LED floor position indicator‡
- Automatic car lighting
- Single floor designated car homing
- Uninterruptible Power Supply (UPS) for car lowering and automatic car gate/door operation (if provided) in the event of a power failure\*\*

## Car Features

- Car size up to 15 square feet
- 7'0" interior car height
- Birch, Oak or Maple flat veneer interior walls with flat ceiling\*
- Matching wood handrail
- Matching wood car sill
- Unfinished plywood floor with sill set for ¾" (flooring by others)
- Two energy-saving recessed LED lights with Black trim rings
- 7'0" vinyl laminate accordion door (Light Oak, Dark Oak, Birch, White, Chalk or Antique White)

*This brochure is intended for INFORMATIONAL PURPOSES ONLY and SHOULD NOT be used for construction.*

## Optional Features

- Up to six stops
- Single automatic push-button operation
- Custom car size up to 18 square feet\*\*
- Custom car height
- Shaker or Recessed panel car with flat ceiling
- Shaker, Recessed or Raised panel car with matching ceiling
- Four recessed LED lights with Black, Polished Brass, Brushed Nickel or Bronze trim rings
- Factory-finished car
- Polished Stainless Steel, Polished or Brushed Brass, Black, Vintage Bronze and Oil-Rubbed Brass fixtures (including COPs, phone boxes, hall calls and handrails)
- COP with integrated keypad phone
- Custom wood interiors
- Custom factory finish, Distressed\*
- "Green" material alternatives and finishes for car interiors\*
- ¾" finished or unfinished installed hardwood car flooring
- Factory flooring insert for ¼" flooring by others
- Buffer springs (require minimum of 8¼ inch pit depth)
- Key switch for COP and/or hall stations
- Rated capacity: 750 lbs.

## Car Gate/Door Options

- Symmetry Safety 3-Panel car door
- Two and three speed car door or car and landing doors
- Wrap around car door‡
- Enterprise collapsible gate
- Hardwood veneer accordion door
- Clear acrylic panel accordion door
- Automatic car gate/door operator (not available on the Enterprise collapsible gate)

*NOTE: Accordion doors will have Bronze hardware except on White, Chalk or Antique White doors. Acrylic accordion doors will have Clear hardware when Stainless Steel or Black fixtures are provided.*

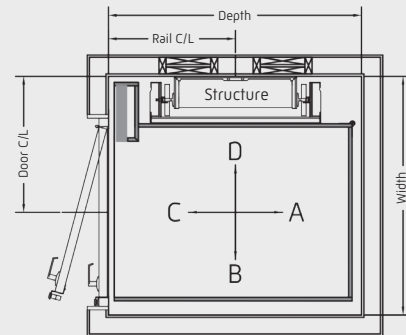

Car Gate/Door	Car Size	Width	Depth	Rail C/L	Door C/L	Clear Opening
Accordion or Collapsible (1)	36X48	50½"	54¼"	27½"	28¾"	33½"
	36X60	50½"	66¼"	33½"	28¾"	33½"
	40X54	54½"	60¼"	32"	32¾"	33½" (2)
Symmetry Safety 3-Panel	36X48	52"	55"	31"	30¼"	33"
	36X60	52"	67"	33½"	30¼"	33"
	40X54	54½"	61"	31"	32¾"	33" (2)

(1) Collapsible gates will have a clear opening approximately 1" less than shown  
 (2) 36" clear opening available-door centerlines may change

\* Symmetry Elevating Solutions exclusive

\*\* May require approval from the local authority having jurisdiction

† Depends upon the package ordered

‡ Availability depends on the code year

§ Standard finish is Brushed Stainless Steel, but multiple finishes available

